

8 7 6 5 4 3 2 1

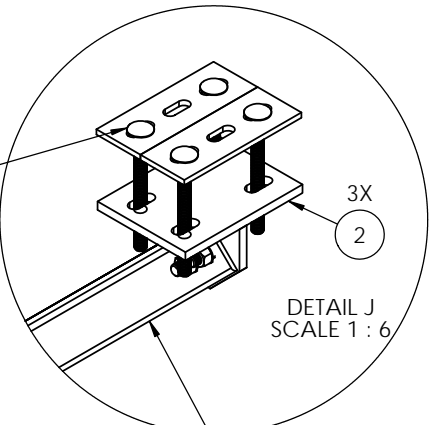

ITEM NO.	PART NUMBER	DESCRIPTION	QTY.
1	T1503KT40A	Universal ring mount 10"-40" Kit	1
2	K1730KT-05	Support Weldment, T-Arm Stabilizer	3
3	Z2026KT-01	Mounting Weldment, T-arm Stabilizer	3
4	K1730KT-06	Standoff Angle for Sector Frame, 52"	6
5	K4000KT	Plate for work support T-arm	6
6	H1029KT17GCB	Carriage Bolt, 5/8"-11 x 7", Full Thread	12
7	H1029KT214GA3	Bolt, 5/8"x2-1/4" (A325) HH, HDG	24
8	H3012KT58GSA3	Flat washer, 5/8", SAE (A325), HDG	48
9	H3002KT58G	Lock washer, 5/8", HDG	36
10	H2002KT58GA3	Nut, 5/8"HH, HDG (A325)	36
11	K1032KT214-2	5/8" x 2-1/4" A325 bolt kit (4 bolts)	3
12	K2220KT121A	Threaded rod kit 5/8" x 12"(4 rods)HDG	1
13	K1000KT8-534	Half Clamp, Medium 5-3/4" Center	2

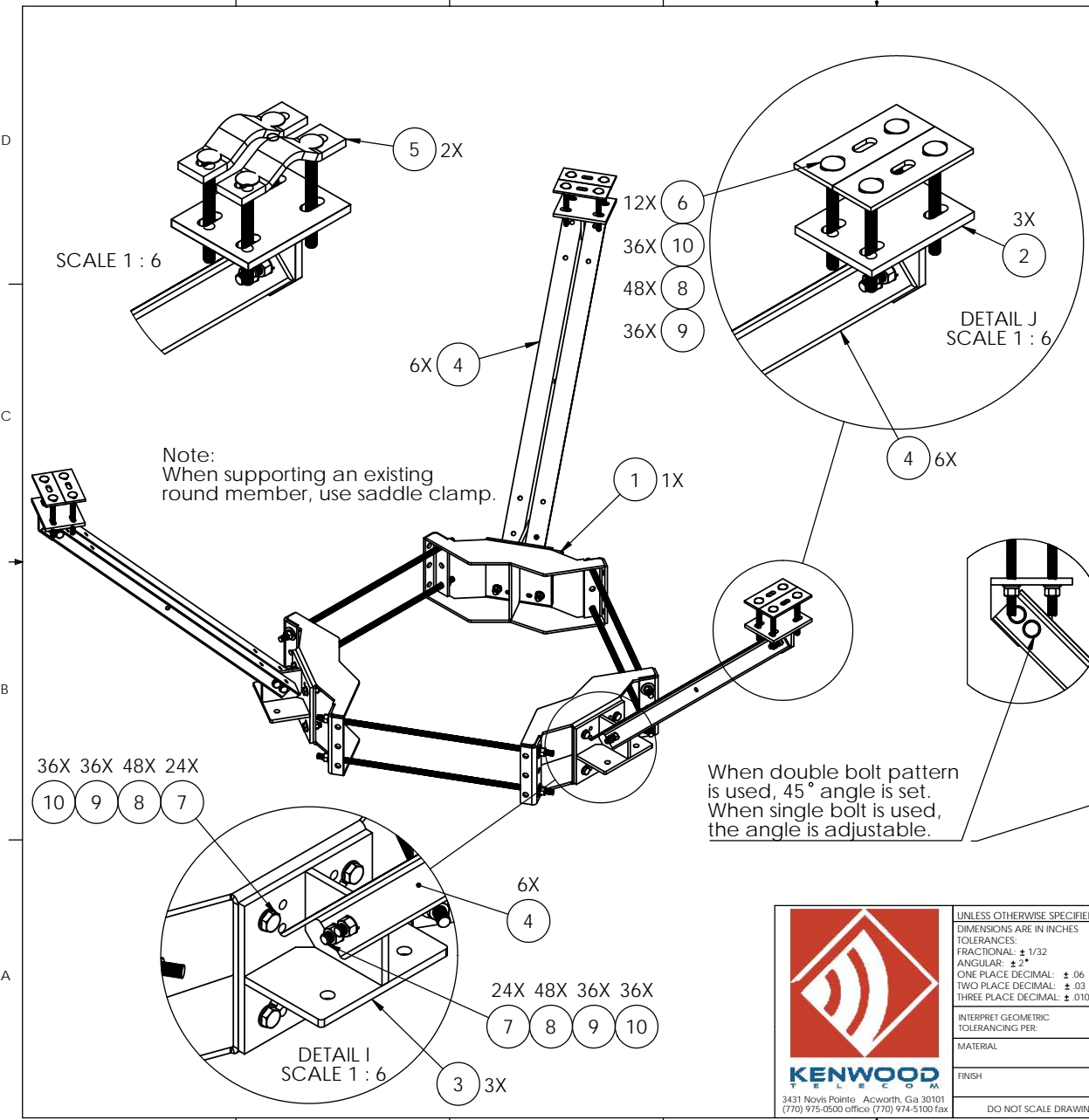
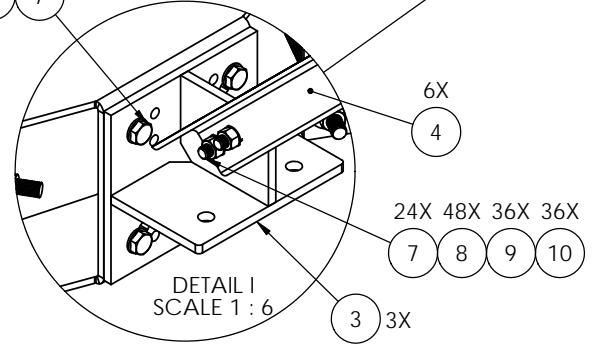
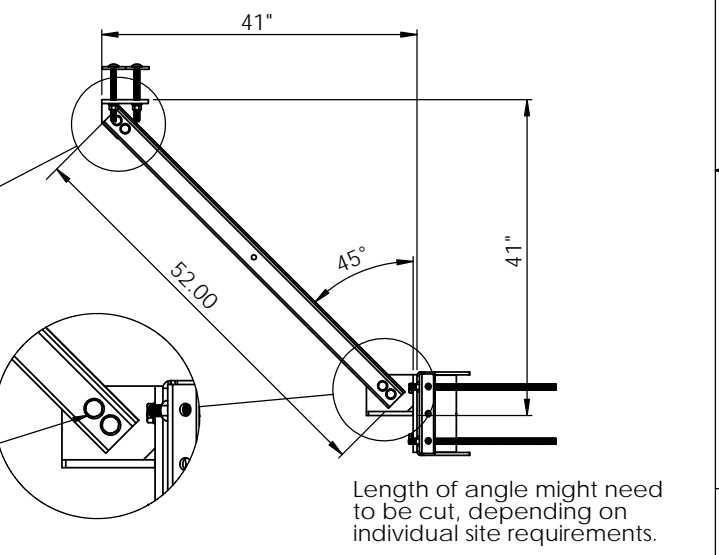

UNLESS OTHERWISE SPECIFIED: DIMENSIONS ARE IN INCHES TOLERANCES: FRACTIONAL: ± 1/32 ANGULAR: ± 2° ONE PLACE DECIMAL: ± .06 TWO PLACE DECIMAL: ± .03 THREE PLACE DECIMAL: ± .010		NAME KAR	DATE 2/19/15
INTERPRET GEOMETRIC TOLERANCING PER:	PROPRIETARY AND CONFIDENTIAL		
MATERIAL:	THE INFORMATION CONTAINED IN THIS DRAWING IS THE SOLE PROPERTY OF KENWOOD TELECOM. ANY REPRODUCTION IN PART OR AS A WHOLE WITHOUT THE WRITTEN PERMISSION OF KENWOOD TELECOM IS PROHIBITED.		
FINISH:	DO NOT SCALE DRAWING		

KENWOOD TELECOM

TITLE: Stabilizer/Support Assembly for existing monopole mounts W/Ring Mount

SIZE	DWG. NO.	REV
SCALE: 1:16	T1730KT-S	F

WEIGHT: 232.15 SHEET 1 OF 1

8 7 6 5 4 3 2 1